

Templates

Preparation of Top Latch for SVR/3PT

Top Latch & 106/106Z Strike

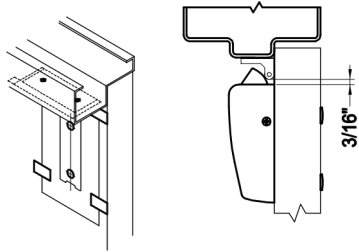

Top Latch & 108 Strike

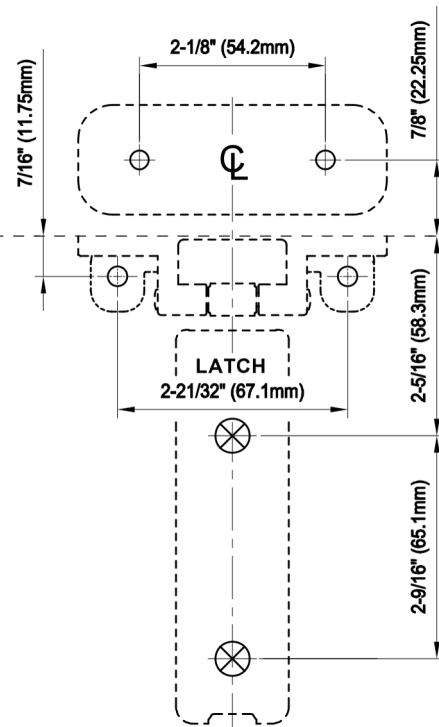
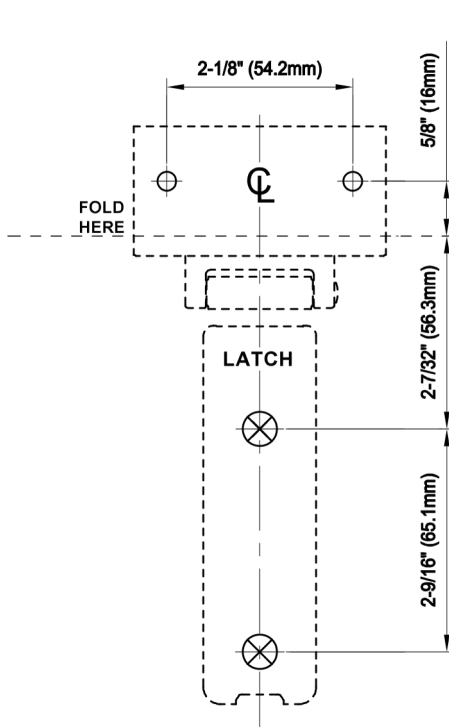
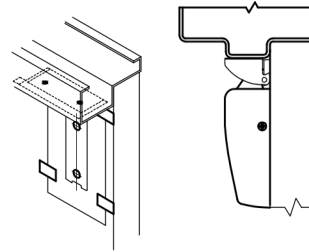

Illustration	Applications	Dimension	
		Metal	Wood
○	Strike Screw	#25 Drill #10-24 Tap	1/8" (3mm) Drill Pilot 1" Deep
⊗	Sex Bolt	5/16" (8mm) Drill (Device Side) 13/32" (10.3mm) Drill (Outside)	

OAK P Series Service Manual

Templates

Preparation of Top Latch for CVR

Top Latch & 216 Strike

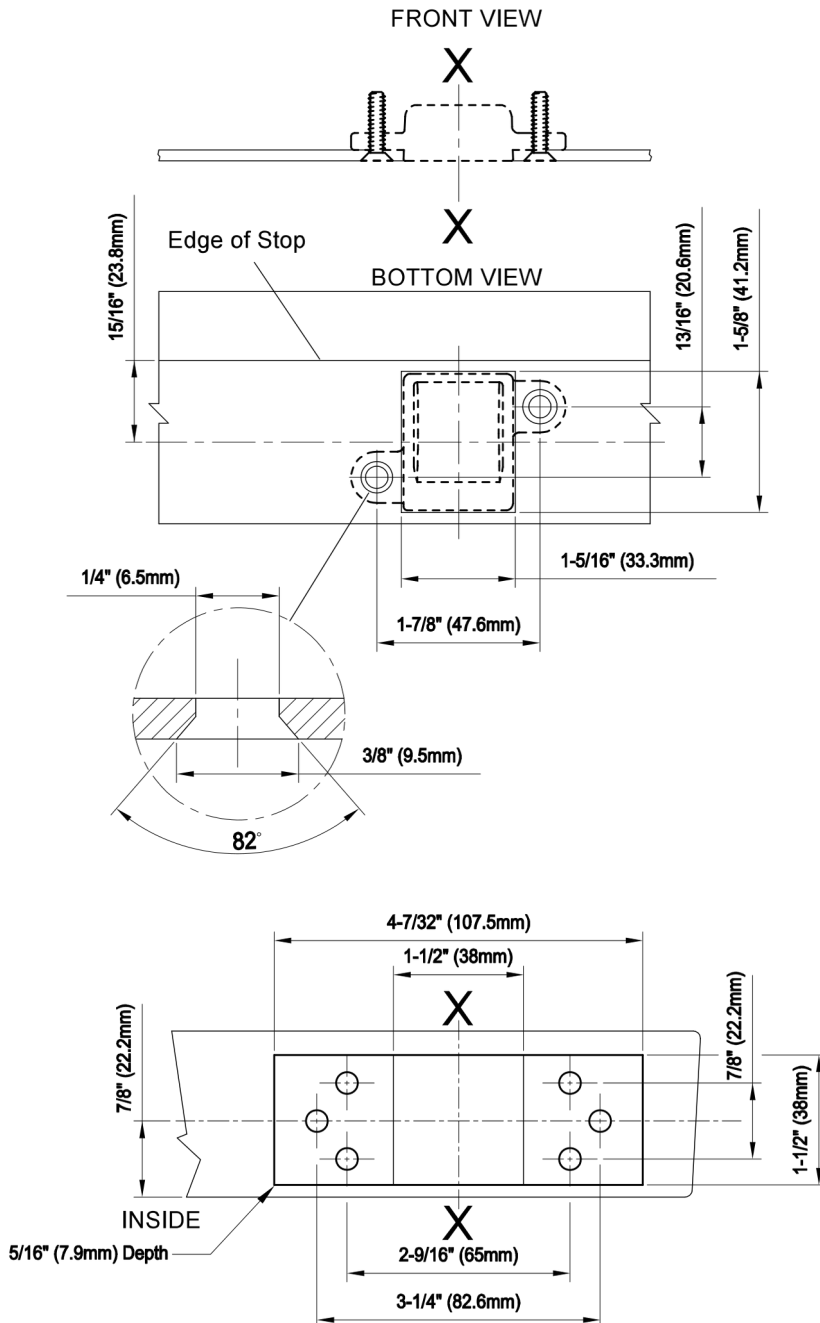

Release Plunger

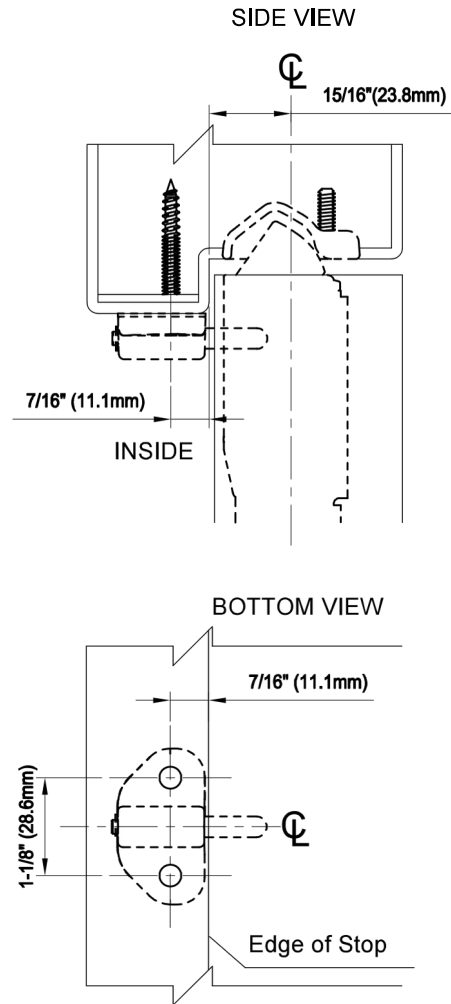

Illustration	Applications	Dimension	
		Metal	Wood
O	Latch & Release Plunger	#25 Drill #10-24 Tap	1/8" (3mm) Drill Pilot 1" Deep