

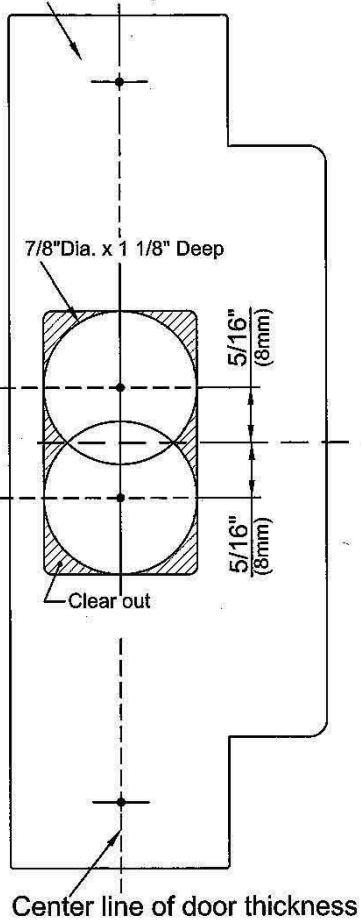

Toll free : 1-877-674-5625
www.oaksecurity.com

1CL & 2CL LEVER CYLINDRICAL TEMPLATE

Frame Prep. for Strikes
 Recess to fit Strike Plates



Door Edge Prep. for Latch
 Recess to fit Faceplate

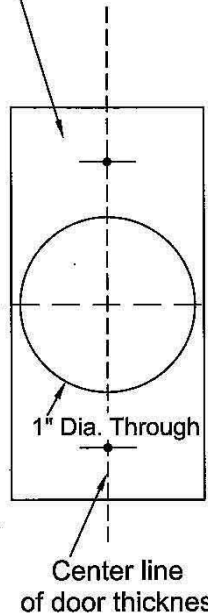

IMPORTANT :
 Check door thickness
 before drilling.

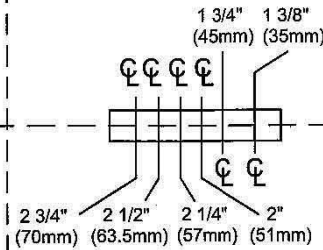

Drill 1" (25mm) Dia.
 Hole on Door Edge
 Center Line

For Wood or Metal Door

Drill two 5/16" dia. holes on vertical center line
 from both sides of door.

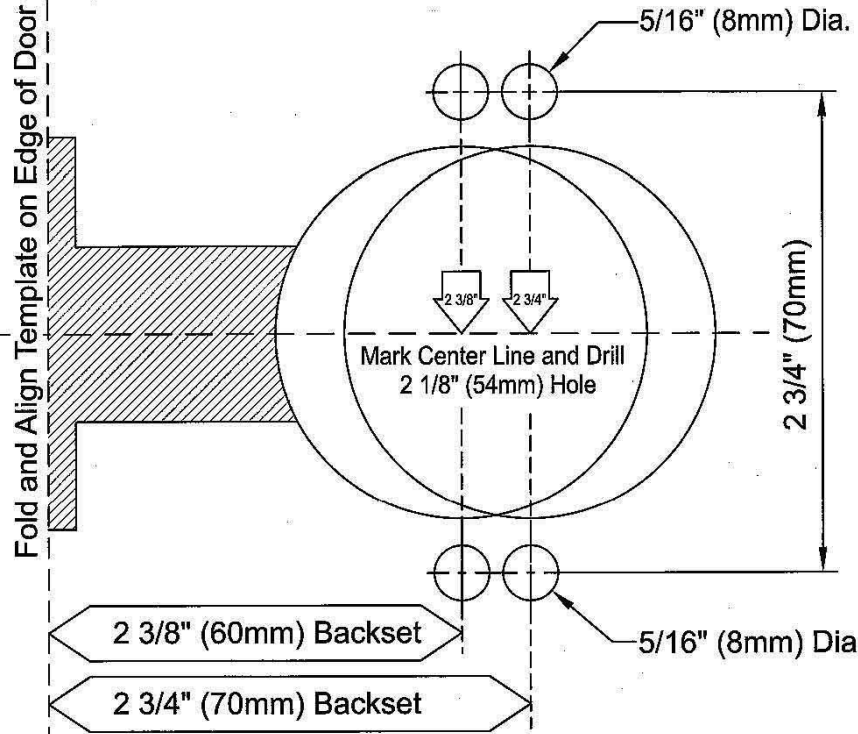

Place Template on High Edge of Bevel